

MODEL STC-100 SPECIFICATIONS



GENERAL SPECIFICATIONS

CRANE CAPACITY RATING	57,000 FT. LBS.	7.87 TM
MAXIMUM REACH	22' 6"	6.85 M
TIP HEIGHT *	25' 7"	7.80 M
HYDRAULIC EXTENSION	108"	274.3 cm
ROTATION (STANDARD)	360 DEGREE CONTINUOUS	
CRANE WEIGHT	1950 POUNDS	884.7 KG
STORAGE HEIGHT (CRANE ONLY)	41.2"	104.6 cm
OUTRIGGER SPAN (OPTIONAL EQUIPMENT)		
RETRACTED	95"	241.3 cm
EXTENDED	143"	363.2 cm
MOUNTING PLATE DIMENSIONS	24" X 24"	61 X 61 cm
RECOMMENDED PUMP CAPACITY PER MINUTE	10 GALLONS	37.8 LITERS
OPERATING PRESSURE (DIFFERENTIAL)	2500 PSI	172.4 BAR
BOOM ELEVATION RANGE	-15 DEGREES TO + 80 DEGREES	
MINIMUM LOAD RADIUS FROM CENTERLINE	28.5"	72.3 cm

* VERTICAL DISTANCE FROM BASE PLATE TO CENTER OF LOWER SHEAVE TIP PIN

STANDARD EQUIPMENT SPECIFICATIONS

WINCH

BARE DRUM SINGLE LINE PULL	38:1 RATIO WORM GEAR 5000 POUNDS	2268 KG
LINE SPEED -4TH LAYER 1 PART LINE	30 FEET/MINUTE	9.1 M/MINUTE
WIRE ROPE DIAMETER	7/16"	11.1 mm
WIRE ROPE LENGTH	95'	28.9 M
BALL BEARING SWIVEL HOOK	3 TON	2.7 M TON
2 - PART LINE BLOCK	8 TON	7.2 M TON
RATIO CABLE TO SHEAVE PITCH DIAMETER	18:1	
RATIO CABLE TO WINCH DRUM DIAMETER	18:1	

CYLINDERS

BOOM LIFT CYLINDER	5 INCH	127 mm
BOOM EXTEND CYLINDER	3.50 INCH	88.9 mm
LOAD HOLDING VALVES	INTEGRAL COUNTERBALANCE	

ROTATION DRIVE

PLANETARY REDUCTION GEARBOX/
HYDRAULICALLY RELEASED BRAKE

DIRECTIONAL CONTROL VALVE

OPERATION
CONTROL PENDANT
4 SECTION STACKABLE
SOLENOID WITH MANUAL OVERRIDE
30' (9.1 M) LONG HARD WIRED

OVERLOAD PROTECTION SYSTEM

ACTIVE FUNCTION CUTOUT



HYDRAULIC SYSTEM/POWER SOURCE

The STC 100 is designed for use with an open center hydraulic system when equipped as standard. The system requires an approximate 17.5 horsepower to supply 10 gallons per minute and 2500 PSI. Power supply is generally a direct mounted pump and PTO for truck chassis applications, however other power supplies can be utilized.

Crane utilizes a four section, stackable, electric solenoid operated directional control valve with a 30 foot hard wired pendant control. A pressure relief is not supplied. In instances where a relief cannot be incorporated into other hydraulic system components, the optional inline relief should be ordered.

HOLDING VALVES

The base (extension) end of boom lift and extension cylinders are equipped with pilot operated counterbalance valves built into the cylinder. The counterbalance valve provides protection from boom collapse in the event of a hydraulic system failure or hose break. In addition, the counterbalance valves smooth lowering of the boom under load and also act as a thermal relief to prevent excessive pressure build up due to thermal expansion of the hydraulic oil.

WINCH SYSTEM

The winch is powered by a low-speed high-torque hydraulic motor through a 38:1 ratio worm gear with an automatic mechanical brake for load holding. Winch system is equipped with 95' of 7/16" diameter wire rope of 6 x 25 construction. A ball bearing swivel hook is provided for single line applications and a 2-part line block is provided. Overhaul weights may be optionally supplied.

ROTATION SYSTEM

Rotation is accomplished by a turntable bearing, driven by a low-speed high-torque motor through a planetary reduction gearbox. The drive incorporates a spring applied, hydraulically released brake to lock the system when not functioning. A mounted valve block controls brake release and reset, and also provides counterbalance valves to control smoothing of rotation operation and prevent over-running loads when the crane is rotated on an incline. Continuous rotation provides efficient boom positioning.

OVERLOAD PROTECTION

An active overload protection system is standard. The system senses overload conditions and prevents operation of boom extend and winch raise functions in the event of an overload. Boom retract and winch lower functions remain operational and allow crane operation to alleviate the overload condition. When systems are within rating limits the system will automatically reset to normal operation.

CONTROLS

Equipped as standard, control of the crane is provided by a hard wired remote pendant providing on-off operation of crane functions. Switches provided are military spec sealed toggle, capable of reliable operation in harsh operating environments which may be encountered.

DIMENSIONAL CONFIGURATION

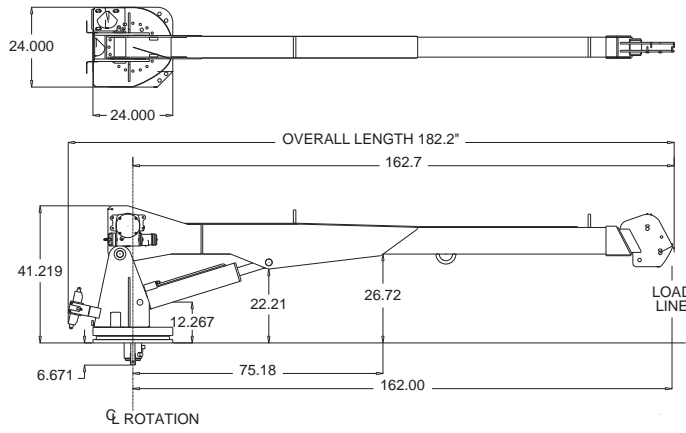

OPTIONAL EQUIPMENT

ELECTO-HYDRAULIC FLOW CONTROL: System provides an electrically controlled variable flow control valve which is operated at the remote control pendant. The valve will allow control of the oil volume supplied to the crane directional valve and therefore will control the crane function operating speeds. This system uses the same control switches as the standard on-off control in conjunction with a variable controller to regulate crane function speeds.

CONTROL PENDANTS: The standard remote pendant can be equipped with a rotary actuator for control of electro-hydraulic flow control system described above.

A hard wired pendant may be optionally supplied which uses an index finger trigger actuator for true one hand control of all crane functions and function operating speeds.

A radio remote control is also available which provides operation of the crane without wired cables and allows complete freedom of movement. The unit is FCC approved and uses a multiple coding system to eliminate any possibility of accidental operation. The radio remote may be equipped for on-off or remote speed control operation.

STABILIZERS: Stabilizer systems can be provided in manual or hydraulic versions. A standard configuration is available or a custom design can be provided for specific requirements.

WINCH OPTIONS: Optional worm gear or planetary winches can be supplied in single speed or two speed versions which can provide line speeds of more than 100 feet per minute single line, using hydraulic flows recommended for standard cranes.

OTHER OPTIONS: A variety of other equipment can be provided to meet the needs of specific applications. Special equipment includes lifting hooks, flow adjusters to allow user changeable selection of maximum crane function speeds, inline relief valves, pallet forks, grapples and other items too numerous to mention. Please contact JOMAC, LTD or your dealer for evaluation of any special requirements you may have.

CAPACITY CHART

