

HFC-8000

SERIES

SPECIFICATIONS



GENERAL SPECIFICATIONS

	8017	8021	8026	8031
CRANE CAPACITY RATING	80,000 FT. LBS.	80,000 FT. LBS.	80,000 FT. LBS.	80,000 FT. LBS.
MAXIMUM REACH (FROM CENTERLINE)	17'	20' 8"	26' 3"	31' 6"
TIP HEIGHT *	27' 4"	30' 6"	35' 3"	40' 6"
HYDRAULIC EXTENSION	36"	66"	132" (2 STAGES)	132" (2 STAGES)
MANUAL EXTENSION	--	--	--	63"
ROTATION (STANDARD)	370 DEGREES			
CRANE WEIGHT	3500 POUNDS	3650 POUNDS	3800 POUNDS	4200 POUNDS
STORAGE HEIGHT (CRANE ONLY)	93.7"	93.7"	93.7"	93.7"
STORAGE WIDTH (BOOM ONLY)	84.2"	94"	95"	95"
OUTRIGGER SPAN (H-FRAME TYPE)				
RETRACTED	97"	97"	97"	97"
EXTENDED	149"	149"	149"	149"
MOUNTING SPACES REQUIRED **	28.75"	28.75"	28.75"	28.75"
MINIMUM PUMP CAPACITY/MINUTE	8 GALLONS	8 GALLONS	8 GALLONS	8 GALLONS
OIL TANK CAPACITY (APPROX)	20 GALLONS	20 GALLONS	20 GALLONS	20 GALLONS

* LIFT HEIGHT WHEN MOUNTED ON 39" (99.06 cm) HIGH TRUCK FRAME.

** ALLOW MINIMUM 4" (10.1 cm) ADDITIONAL BETWEEN CAB AND CRANE FOR ROTATION CLEARANCE. DISTANCE MAY VARY BY TRUCK MODEL.

CYLINDER DATA

	BORE	STROKE
MAIN BOOM CYLINDERS	4.0"	35.812"
FOLDING BOOM CYLINDER	5.0"	42.875"
EXTENSION CYLINDERS		
SINGLE STAGE (8017)	3.0"	36"
SINGLE STAGE (8021)	3.0"	66"
TELESCOPIC STAGE 1 (8026, 8031)	4.0"	66"
TELESCOPIC STAGE 2 (8026, 8031)	2.5"	66"
STABILIZER CYLINDERS (H-FRAME)		
DOWN (STANDARD)	2.5"	24"
EXTEND (OPTIONAL)	1.5"	26"
A-FRAME STABILIZERS	3.25"	37.562"

RECOMMENDED TRUCK CHASSIS

	CONVENTIONAL	CABOVER
WHEELBASE	189" (4800 mm)	164" (4165 mm)
CAB TO AXLE DISTANCE (CA)	120" (3048 mm)	144" (3657 mm)
FRONT AXLE RATING	10000 POUNDS	4536 KG
REAR AXLE RATING	18500 POUNDS	8391 KG
FRAME SECTION MODULUS	22 CUBIC INCHES	361 cc
RESISTING BENDING MOMENT (RBM) 50,000 PSI FRAME	1,100,000 IN. LBS.	12675 KG-M



COUNTERBALANCE SAFETY VALVES

The inner, knuckle and extension boom cylinders are equipped with pilot operated counterbalance valves integral to the cylinder on the load holding sides. The stabilizer cylinders are equipped with dual pilot operated check valves. The counterbalance valves positively hold the load during normal operations. The valves additionally provide collapse protection in event of a hydraulic system failure or hose break. The counterbalance valves further control the metering of lowering functions and provide thermal relief protection in event of hydraulic oil expansion due to ambient temperature conditions. The dual pilot operated check valves positively lock the cylinder in position until the operator intentionally controls that function.

ROTATION SYSTEM

Slewing is accomplished by means of a rotation turntable bearing driven by a low-speed, high-torque motor through a reduction gearbox by means of a spur gear pinion.

HYDRAULIC SYSTEM

The 8000 hydraulic system utilizes a PTO driven pump providing the minimum 8 gallons per minute hydraulic flow at 2600 PSI system pressure. An eight section stack type valve is provided as standard equipment. The standard 8000 crane configuration utilizes 6 of the valve sections, with the remaining two sections plugged, but available for use with optional equipment. Dual control stations are provided for all eight valve sections. The complete hydraulic system includes the hydraulic tank, suction line strainer, pump, 8 section directional control valve, return line filter and all required hoses and fittings.

8017 LOAD CHART

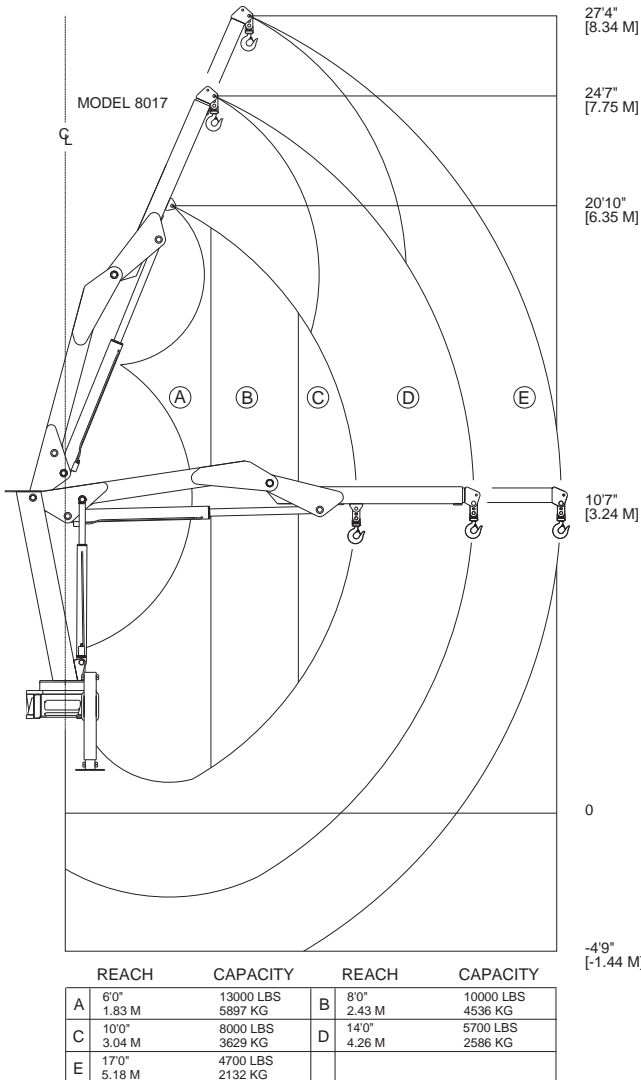

DEDUCT WEIGHT OF LOAD HANDLING DEVICES

OPTIONAL EQUIPMENT AVAILABLE

BOOM OPTIONS: The 8000 series is available with several boom configurations to meet various reach requirements. The shortest available boom is model 8017 with reach to 17 feet. Model 8021 has one hydraulic extension. Model 8026 has two hydraulic extensions and model 8031 has two hydraulic extensions plus a manual pullout.

STABILIZER OPTIONS: The 8000 series cranes are available with either H-Frame out and down type stabilizers or A-Frame angled stabilizers.

HYDRAULIC STABILIZER EXTENSION: Provides two each 2.00" bore cylinders for hydraulic extension of stabilizers. This option utilizes the 7th and 8th valve sections unused with the standard crane. This option available for H-Frame type outriggers only.

HYDRAULIC WINCH: Boom mounted winch system provides hydraulic motor driven winch with 5000 pounds (2268 KG) single line pull. Winch option is equipped with complete hydraulic winch installed with 85 feet (25.9M) of 7/16" (11.1 mm) diameter cable, moveable sheave block and ball bearing swivel hook with latch. An additional directional valve is included when crane is also equipped with optional hydraulic stabilizer extensions.

ANTI TWO-BLOCK SYSTEM: Boom tip weighted switch and 2 unloading solenoid valves are provided to stop boom extension and winch raise functions in event of accidental operation of the winch hook into the boom tip. System provides protection of crane components and ensures operator safety. This option available only with above hydraulic winch option.

CABLE REMOTE CONTROL SYSTEM: Option provides solenoid operated directional control valves for control of all crane functions except stabilizer functions. System includes solenoid operated directional control valve and toggle switch operated remote control pendant with 35' (10.6M) cable.

RADIO REMOTE CONTROL SYSTEM: Option utilizes the same solenoid operated direction valve as cable remote above except is provided with a hand held control which functions by radio wave transmission and eliminates the attached cable thereby allowing unrestricted operator movement during crane operation. System has a range of more than 200' (60.9M) and uses multiplexing signal control to assure there is no interference from other radio signals. FCC approved.

PROPORTIONAL SPEED CONTROL SYSTEM: Option incorporates a electrically controlled variable flow control valve which provides speed control of crane functions. Function speed can be varied from no movement to full speed at maximum system flow. This optional system can be used with either cable or radio remote control systems.

A-FRAME OUTRIGGER CONFIGURATION

