

HFC-1815

SERIES

SPECIFICATIONS



GENERAL SPECIFICATIONS

CRANE CAPACITY RATING	18,000 FT. LBS.	2.50 TM
MAXIMUM REACH (FROM CENTERLINE)	15'	4.57 M
TIP HEIGHT *	23' 11"	7.28 M
HYDRAULIC EXTENSION	36"	91.4 cm
ROTATION (STANDARD)	360 DEGREES	
CRANE WEIGHT	850 POUNDS	385.6 KG
STORAGE HEIGHT (CRANE ONLY)	68.5"	174.5 cm
STORAGE WIDTH (BOOM ONLY)	74.35"	188.8 cm
MOUNTING SPACE REQUIRED	18.50"	46.9 cm
MINIMUM PUMP CAPACITY/ MINUTE	3 GALLONS	11.4 liters
OIL TANK CAPACITY (APPROX)	10 GALLONS	37.9 liters

* LIFT HEIGHT WHEN MOUNTED ON 34" (86.4 cm) HIGH TRUCK FRAME

CAPACITY CHART
WORKING RANGE

AREA	REACH	CAPACITY	AREA	REACH	CAPACITY
A	6 FEET	3000 LBS.	C	12 FEET	1500 LBS.
	1.83 M	1361 KG		3.66 M	680 KG
B	9 FEET	2000 LBS.	D	15 FEET	1200 LBS.
	2.74 M	907 KG		4.57 M	544 KG

CYLINDER DATA

	BORE	STROKE
MAIN BOOM CYLINDERS	2.50" (6.3 cm)	30.125" (76.5 cm)
FOLDING BOOM CYLINDER	2.75" (6.9 cm)	34.312" (87.2 cm)
EXTENSION CYLINDER	2.00" (5.0 cm)	36.00" (91.4 cm)

LOAD RATINGS

6' (1.83 M)	3000 POUNDS	1361 KG
9' (2.74 M)	2000 POUNDS	907 KG
12' (3.66 M)	1500 POUNDS	680 KG
15' (4.57 M)	1200 POUNDS	544 KG

WEIGHTS OF LOAD HANDLING DEVICES MUST DEDUCT FROM ABOVE CAPACITIES.

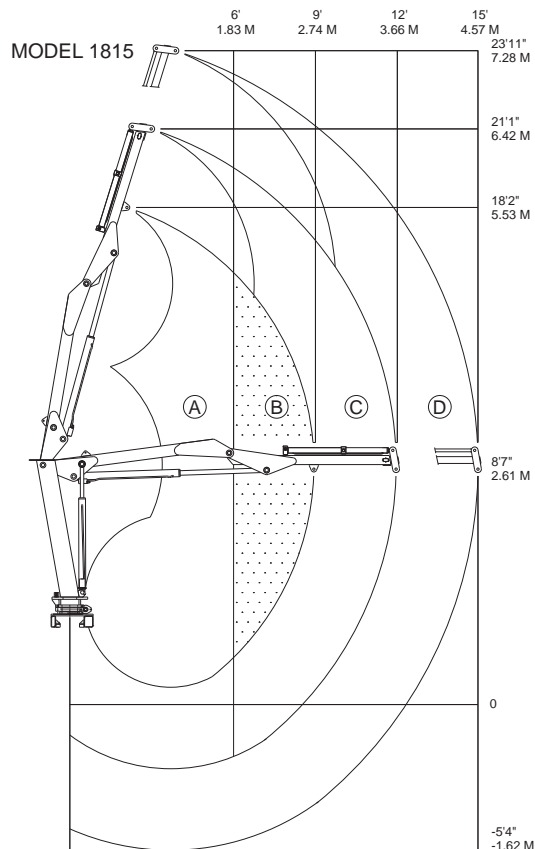

DEDUCT WEIGHT OF ANY LOAD HANDLING DEVICES FROM CAPACITIES SHOWN



COUNTERBALANCE SAFETY VALVES

The main (inner) boom and knuckle (articulating) boom cylinders are equipped with pilot operated counterbalance valves integral to the cylinder on the load holding sides. The boom extension cylinder is equipped with dual pilot operated check valves.

The counterbalance valves positively hold the load during normal operations. The valves additionally provide protection in event of a hydraulic system failure or hose break. The counterbalance valves further control the metering of lowering functions and provide thermal relief protection in event of hydraulic oil expansion due to ambient temperature conditions.

The dual pilot operated check valves positively lock the cylinder in position until the operator intentionally controls that function.

ROTATION SYSTEM

Slewing is accomplished by means of a rotation turntable bearing driven by a self locking external helical worm gearbox powered by a low-speed, high-torque motor. Total reduction is 61:1.

HYDRAULIC SYSTEM

The standard HFC 1815 series crane is powered by a PTO driven hydraulic pump. The hydraulic gear pump provides approximately 3.5 gallons per minute of hydraulic flow. The system includes a 10 gallon capacity hydraulic tank with suction and return line filtration.

Optional power sources may be utilized.

AVAILABLE EQUIPMENT

MANUAL VALVE OPERATION: Provides a manually operated crane control system, operational from the base of the crane. System includes relief valve and all required system components.

REMOTE CONTROL OPERATION: Provides a solenoid operated valve which is controlled remotely by means of a hand held pendant. System also includes an electro-hydraulic proportional valve which allows the operator to remotely control function speeds in addition to basic on-off functions. System includes all components to provide remote control operation.

REMOTE CONTROL OPTIONS: Remote control operation can be accomplished by means of a hard wired system, using a remote control pendant with 30 feet of cable. This system utilizes quick connectors for ease of connection of remote harness.

Remote operation may also be accomplished by use of a wireless radio control system. This system eliminates the cable harness and allows complete freedom of movement while operation the crane. The radio control system will also provide operation of the remote speed control system.

DIMENSIONAL CONFIGURATION

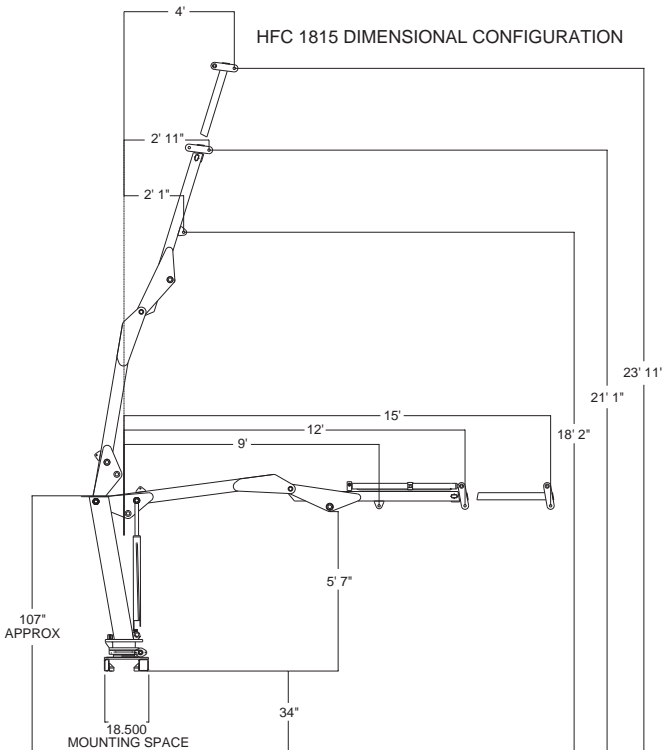

MOUNTING CONFIGURATION OPTIONS

The HFC 1815 can be configured for BEHIND CAB, CORNER OR PEDESTAL MOUNT versions. The typical behind cab installation utilizes A-Frame type outriggers with the crane positioned between the truck frame rails. The unit may also be installed in a corner position behind the cab to allow additional space for installation of air compressors or other equipment. Many corner mount installations are at the rear of the chassis frame. In these instances the crane is typically equipped with H-Frame type outriggers to allow outrigger extension on the crane mounting side. Pedestal mount version delete the outriggers entirely, and are used in fixed installations such as in plant or onboard ship.

Many variations of the basic configurations have been produced. JOMAC can produce a version to meet your application requirements. As it is nearly impossible to document all versions previously produced, please contact your dealer or JOMAC for assistance in special applications.

